

# SmartLane

## Datasheet

Rev. 03 • Update 02/2022

**AUTOMATIC**  
SYSTEMS

«SmartLane»™



### DESCRIPTION

1. Self-supporting frame (made from galvanized steel) integrating the electromechanical drive assembly for each mobile leaf, the cells for the detection of the presence of users, and the control boards.
2. Brushed AISI 304L stainless steel housing.
3. Brushed AISI 304L stainless steel side panels with key lock, allowing easy access to the electromechanical unit and the control boards.
4. Monolithic clear 12 mm thick tempered glass leaf, retracting completely into the body on opening.
5. Aesthetic top cover made of 8 mm thick tempered glass with black screen-printed glass that is highly scratch-resistant and allows the integration of contactless readers and dynamic status light. <sup>[1]</sup> Seamless integration of contactless readers (RFID, QR Code, NFC) under the glass top.
6. Dynamic orientation light indicating the status of the corridor. Allowing good visibility from a distance. Ensuring a high volume of throughput.
7. Dynamic status light, near the reader integration area, indicating the user's clearance.
8. Proprietary DIRAS detection system, consisting of a high density matrix of transmitter/receiver photoelectric cells. The DIRAS system tracks the progress of users in the walkway and ensures their safety when opening and closing obstacles.
9. Electromechanical unit consisting of :
  - A three-phase asynchronous reduction motor.
  - Secondary transmission with crank-and-rod linkage ensuring perfect mechanical locking in both extreme positions.
  - An intrinsic mechanical device for automatic opening of the mobile leaves in the event of a power failure.
  - A variable-speed controller ensuring progressive accelerations and gradual decelerations, for a movement without vibration and for protection of the mechanism and the users in the event of contact with the mobile leaves.
  - An inductive sensor controlling the position of the mobile leaf.
10. Electronic control logic for advanced traffic management with integrated web server, accessible via any web browser, offering a simple interface for configuring the functional parameters of the lane as well as a comprehensive diagnostic and maintenance tool. This maintenance interface, common to several Automatic Systems products, simplifies product maintenance. The Smartlane can also be managed by the 'Smart & Slim' supervision panel and/or the 'Smart Touch' interactive control panel.
11. Transfer of information :
  - Externally via XML-RPC protocol through an Ethernet interface ;
  - By potential-free contacts : passage authorization, passage information, defect, state of the gate (free, prohibited, alarm...).

<sup>[1]</sup> For mobile leaves higher than 1000 mm in height: obstacles (mobiles and fixed) sit in a stainless steel channel.



Designed for intensive use in intra-building sites, the **SmartLane** security entrance lane provides dissuasive control of pedestrians taller than 1 m, with or without luggage, in both directions.

Available in **standard lane (600 mm clear walkway)**, compatible with more constrained installation spaces and **wide lane (900 mm clear walkway)**, ensuring easier access.

With its mechanical design and embedded electronics, the equipment guarantees a high level of security (prevention of fraud) and a high level of safety (protection of users during operation).

The **SmartLane** is a modular product, which can be installed in single or multiple lanes and combined with standard and wide passages within the same battery.



Wide lane + standard lane



## STANDARD TECHNICAL CHARACTERISTICS

Power supply <sup>(2)</sup>	Single phase 230 VAC - 50/60 Hz + Ground
Motor	Three-phase asynchronous 0,12 kW
Consumption <sup>(3)</sup>	Standby 100 W Operating 150 W Maximum 315 W
Ambient operating temperature	0 to +50 °C
Relative ambient humidity	<95%, without condensation
Min. opening or closing times <sup>(4)</sup>	Opening time: 0,7 s Closing time: Min. 0,8 s depending on configuration
MCBF (Mean cycles between failures)	<b>10,000,000</b> cycles, in compliance with recommended maintenance <sup>(5)</sup>
IP rating	IP40
	Complies with European standards <sup>(6)</sup>

STANDARD LANE		
Passageway(s) [L]	600 mm	
	Left/Right	Intermediate
Net weight (kg) <sup>(7)</sup>	140	180

WIDE LANE		
Passageway(s) [L]	900 mm	
	Left/Right	Intermediate
Net weight (kg) <sup>(7)</sup>	180	225

(2) Not to be connected to a floating network or to a high-impedance earthed industrial distribution network.

(3) Per lane.

(4) Minimum manoeuvre times, which can be set, excluding the access control system's action time. The function of memorizing the passage requests allows to accelerate the flow: no closing of the obstacle between 2 requests.

(5) Maintenance operations are detailed in the product's Technical Manual.

(6) The safety profile on mobile leaf option is necessary to comply with the norms related to impact force.

(7) With mobile obstacles H:1000, without option.

## PRECAUTIONS FOR USE

- For safety reasons, users (children) shorter than 1 m must be supervised by an adult at all times when in the vicinity of the unit and when passing through the gate.
- When the gate is used by a child accompanied by an adult, the child must precede the accompanying adult.

## WORKS TO BE PROVIDED BY THE CUSTOMER

- Fixing the unit to the floor.
- Power supply.
- Cabling between lanes in the same array.
- Cabling to any external peripherals.
- Integration of any accessories.

**Note** : Comply with the installation drawing.

## OPTIONS

1. High glass mobile obstacles: 1200, 1500, 1700, 1800, 1900 or 2000 mm. <sup>(8)</sup>
2. Top cover in stainless steel with dynamic status light(s) and reader screen(s).
3. Top cover in black laminate with dynamic status light(s).
4. Housing extension, per direction (A or B) <sup>(9)</sup>
5. Housing extension with stainless steel infill panels, per direction (A or B) <sup>(9)</sup>
6. Painted stainless steel housing. <sup>(10)</sup>
7. PVD coated stainless steel housing. <sup>(11)</sup>
8. Embossed stainless steel side housing. <sup>(12)</sup>
9. Enhanced DIRAS electronic detection, 'Trolley'-type.
10. Early opening cell on extension (per extension).
11. Heating for operation up to -20°C.
12. Electromagnets for obstacles locking in open position in case of power failure.
13. 120V 60Hz power supply.
14. Personalized logo on glass leaves- sticker like sand blasting.
15. Installation template in electro-galvanised sheet steel.
16. 'Smart & Slim': PC for supervision.
17. 'Smart Touch': panel PC for supervision.

**Note** : For restrictions on options, please contact your sales manager for more information.

(8) High obstacles will automatically introduce:

- The corresponding fixed obstacle.
- Safety detection on fixed obstacles.

(9) DIRAS detection will be integrated in the extensions and allows:

- Anticipated opening in free mode.
- A higher level of detection (prevention of infringements).

(10) Finely structured matt paint RAL to be selected amongst the offered configurations.

(11) Colour to be selected amongst the offered configurations.

(12) Pattern to be selected amongst the offered configurations.

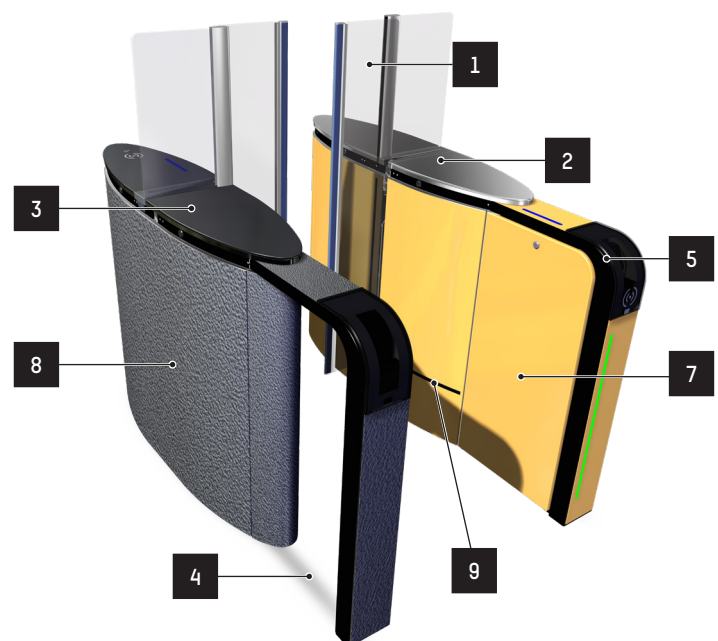

**STANDARD DIMENSIONS (MM)**

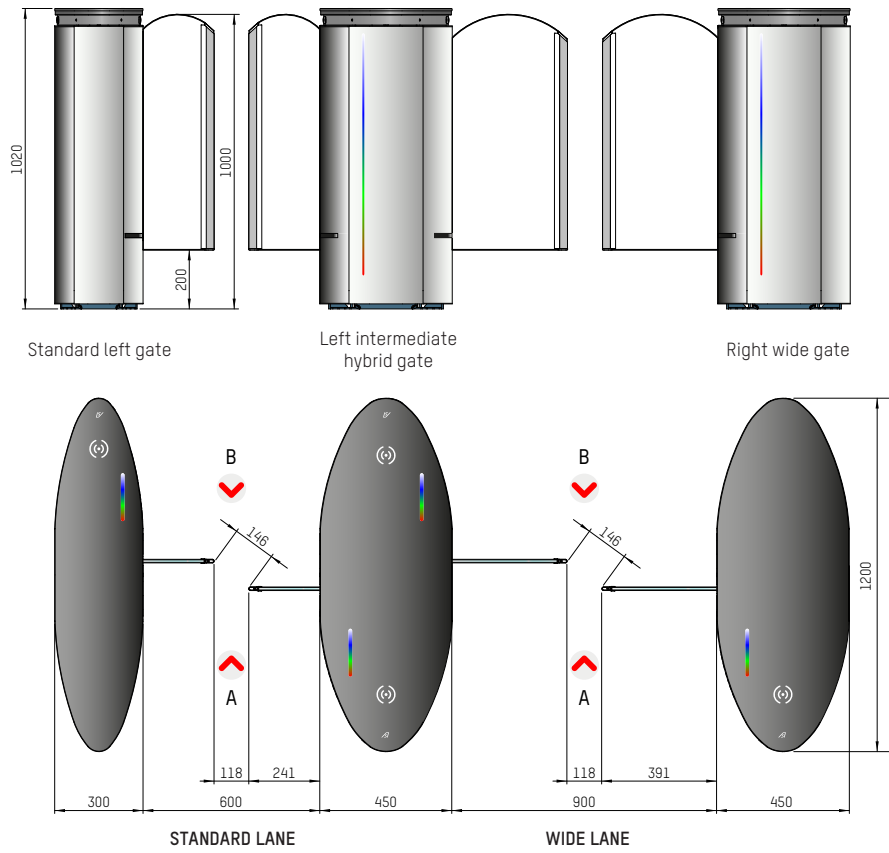

**DIMENSIONS WITH OPTIONAL EXTENSIONS (mm)**

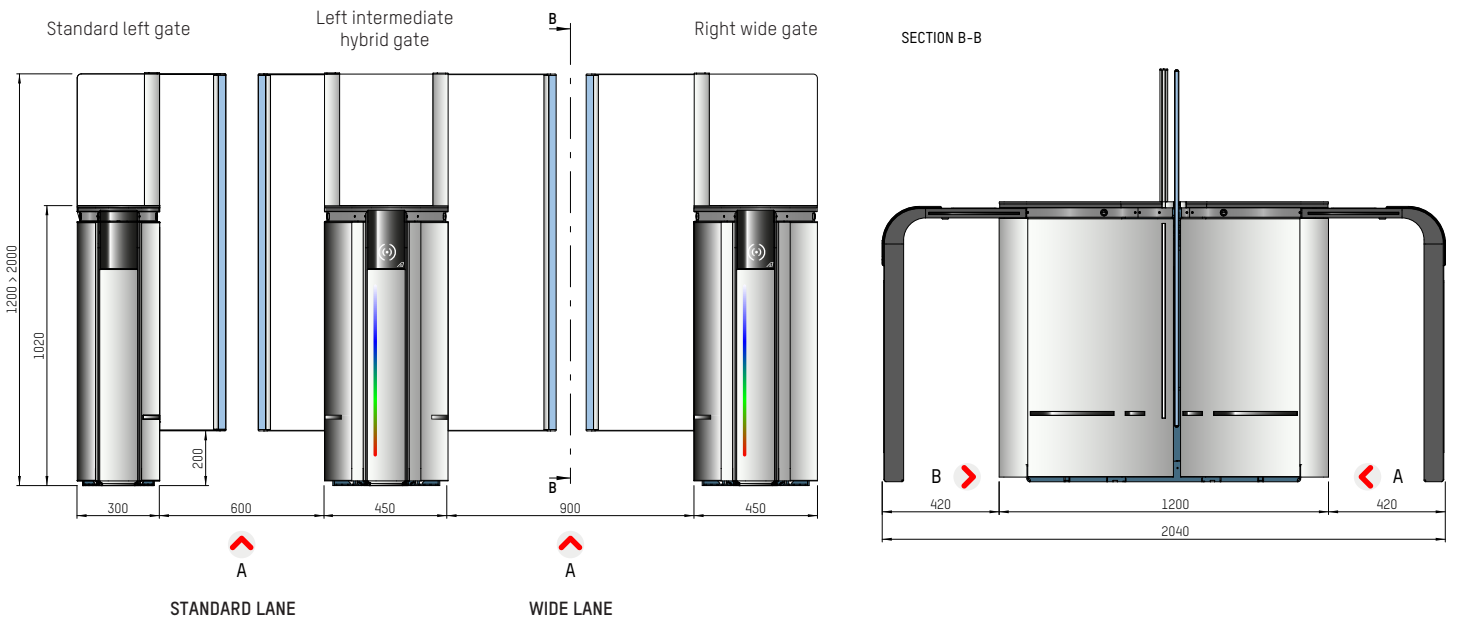

**MAXIMUM VOLUMES AVAILABLE FOR READER INTEGRATION \***

\* For all requests, please contact your sales manager for more information.

**WIDE GATE**

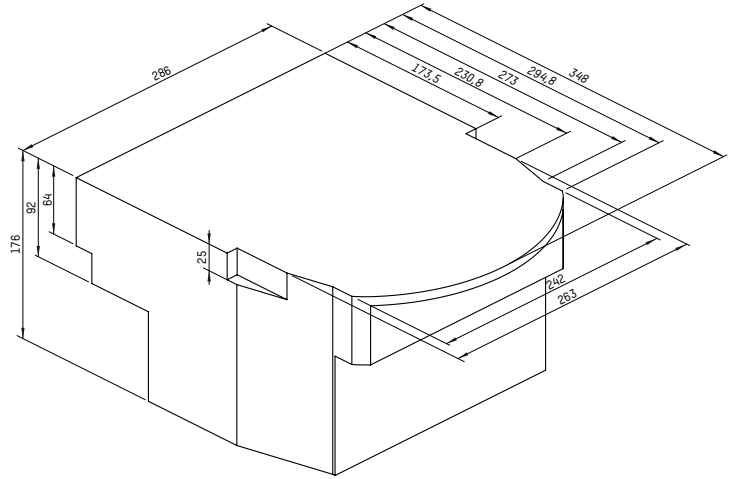
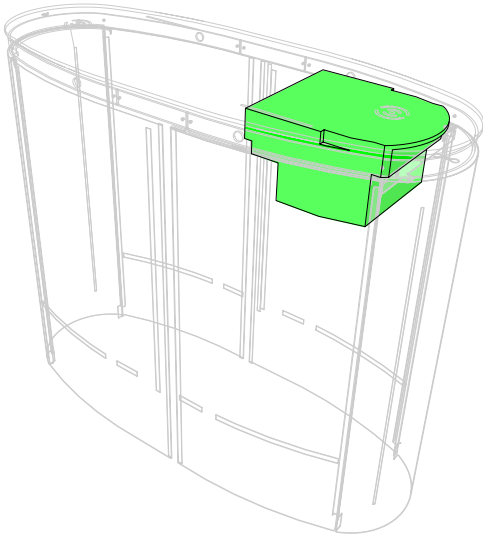

**STANDARD GATE**

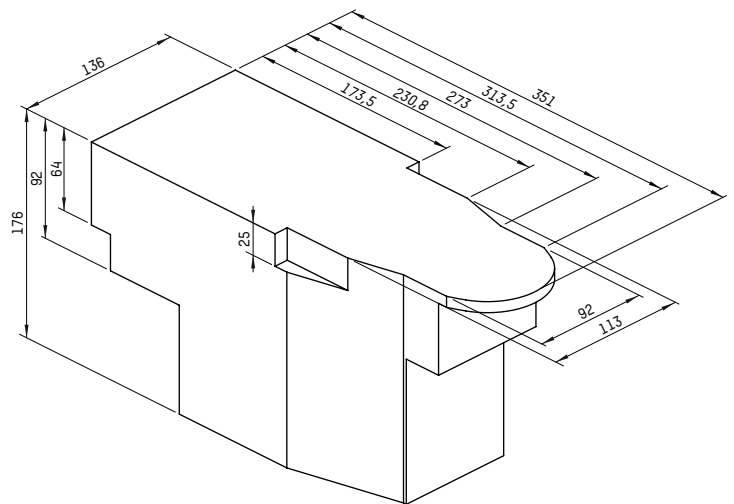
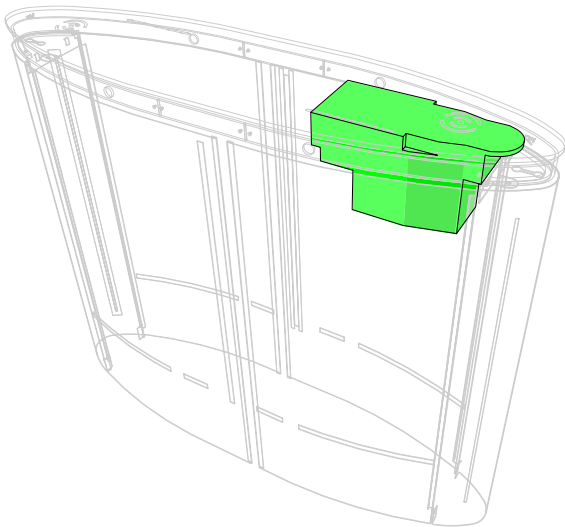

## HOUSING EXTENSION WITH/WITHOUT STAINLESS STEEL INFILL PANELS

